

TORSION SPRINGS SPECIFICATION FORM

Torsion springs are designed to operate over a mandrel. They are wound left or right hand as required to withstand the loads applied. Spring legs are specified to ensure proper fit and function.

TABLE 1







I  Straight Offset Ends	II  Short Hook Ends	III  Double Torsion
IV  Hinge Ends	V  Straight Torsion Ends	VI  Special Ends

TABLE 2



INDICATE UNITS OF MEASURE (IN & LB), (MM & N)

1. MATERIAL _____

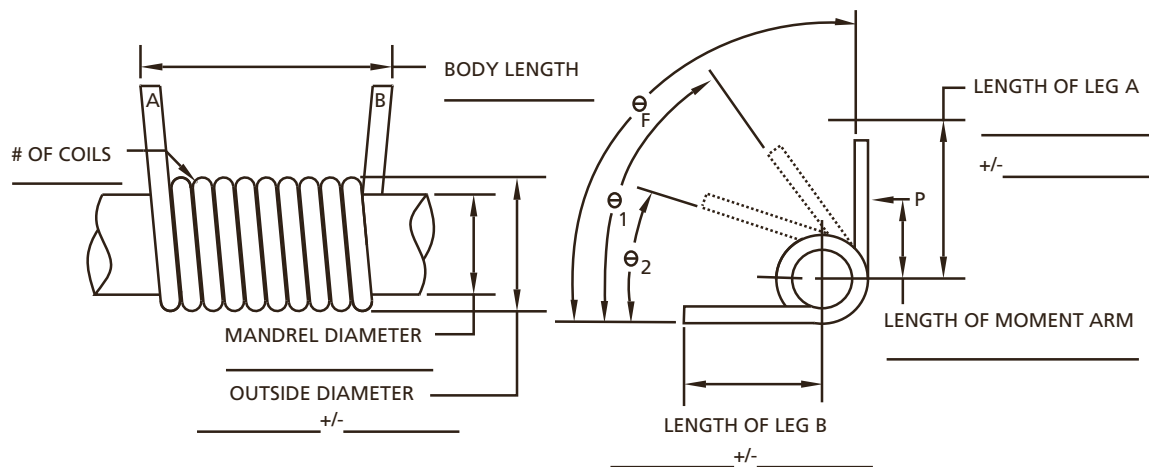
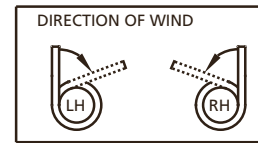
2. WIRE DIA. _____

3. DIRECTION OF WIND LH RH (SEE TABLE 2)

4. END STYLE (A) I II III IV V VI (SEE TABLE 1)

5. STYLE OF END (B) I II III IV V VI (SEE TABLE 1)

6. RATE _____ +/- _____ BETWEEN _____ PER TURN (360°)

7. TORQUE 1 _____ +/- _____ AT \ominus 1 _____ °

8. TORQUE 2 _____ +/- _____ AT \ominus 2 _____ °

9. LENGTH OF SPACE AVAILABLE _____

10. MAXIMUM WOUND POSITION _____ ° FROM FREE POSITION

11. \ominus F _____ FREE ANGLE OR POSITION

12. FINISH _____

13. FREQUENCY OF ROTATION _____ CYCLES/SEC

AND WORKING RANGE \ominus _____ ° TO \ominus _____ ° DEFLECTION

13. OPERATING TEMP _____ °c

QUANTITY TO QUOTE FOR _____

CUSTOMER NAME:	A/C No:	ENQUIRY TAKEN BY:
		DATE TO SUPPLIER:
CUSTOMER CONTACT		DATE PRICE RECEIVED:
TEL No:	EMAIL:	